

DrizAir 80 Dehumidifier

(Models: F214, F214-DX, F214-GS)

Symbol Definition

- * - multiple components to choose from for different models: voltage, size, color, et
- + - if you order this item, you may need to order additional items marked with same number of +'s in order to upgrade or complete repair

Find#	Part Description	Specifications/Model	Part #	Qty
	Connector	Butt Fully Insul 16-14 Ga	02-00013	ea. 1
5	Terminal Block	GP 4 x 4 Screw	02-00078	ea. 1
47	Outlet	Electrical	02-00081	ea. 1
	Wire	Red 14Ga Awm 105c/600v (12")	02-00099	ft. 1'
	Wire	White 14Ga Awm 105c/600v	02-00101	ft. 2.79'
	Wire	Black 14Ga Awm 105c/600v	02-00102	ft. 2'
	Wire	Green 14Ga Awm 105c/600v	02-00103	ft. .75'
	Wire	Orange 14Ga Awm 105c/600v	02-00111	ft. .83'
	Connector	Qc .250 Fem 90 Fully Insul 16/14 Ga	02-00133	ea. 1
	Connector	Piggyback .250 18/14 Ga	02-00134	ea. 1
	Connector	Qc .250 Fem Fully Insul 16/14 Ga	02-00135	ea. 12
41	Strain Relief	Snap .360 Dia Blk	02-00218	ea. 1
	Connector	Ring #10 Insul 16/14 Ga	02-00516	ea. 1
	Connector	14-16 .250 Flag Term compr (Amp) 4000	02-00769	ea. 2
	Switch	Switch-Rocker spst 115v Red W/Splash Grd	02-01471	ea. 1
32	Handle	Flush Mount Blk	03-00002	ea. 1
18	Foot	Round, 3/16 ID x 1.125 OD x .875 Rubber	03-00003	ea. 4
69	Spacer	1 Dia Tube Nylon, Handle (F214-DX)	03-00009	ea. 4
	Cable Tie	Nylon 4"	03-00012	ea. 7
45	Washer	3/16" Rivet Zp	03-00013	ea. 12
6	Screw	#8 x 1/2" Phil Ph Zp	03-00023	ea. 1
58	Cap	Plastic Blk 1.125 Dia. (F214-DX)	03-00027	ea. 1
72	Nut	1/4-20 Nyloc Thin Zp (F214-DX)	03-00029	ea. 2
9	Nut w/ Starwasher	#10-24 w/Star Washer Zp	03-00038	ea. 6
19	Rivet	3/16" x 5/8" Stl/Stl Zp	03-00039	ea. 4
71	Knob	Star 1/4-20 Insert 5/8 Top ID Blk (-DX)	03-00056	ea. 2
28	Plug	.187 Dia Nylon Black	03-00071	ea. 8
73	Bolt	Carriage 1/4-20 x 2 1/4" Zp (F214-DX)	03-00072	ea. 2
2	Screw	#10 x 3/8" AB	03-00079	ea. 13
12	Bolt	5/16"-18 x 1-1/2" Lg Hex Hd Cap Zinc	03-00085	ea. 4
11	Washer	.375 (3/8") ID x .875 (7/8") OD x .07 Zp	03-00086	ea. 8
13	Nut	5/16"-18 Nyloc Zp	03-00098	ea. 4
57	Grommet	.75 ID x 1.375 OD Rubber (F214-DX)	03-00179	ea. 1
1	Rivet	Stl/Stl SB6-4	03-00432	ea. 22
52	Clamp	3/8 ID Hose Green (F214-DX)	03-00471	ea. 1
64	Bolt	Oval Hd Phil 10-24, Axle (F214-DX)	03-00490	ea. 3

Find#	Part Description	Specifications/Model	Part #	Qty
65	Nut	#10-24 Nyloc Zp, Axle (F214-DX)	03-00491	ea. 3
60	Pin	Hitch, #17	03-00501	ea. 2
61	Washer	1/4" x 1/2" x .062 SS (F214-DX)	03-00502	ea. 4
68	Bolt	Oval Hd Phil Mach 1/4-20 x 1 (F214-DX)	03-00503	ea. 4
	Cable Tie	11" (F214-DX)	03-00813	ea. 1
39	Screw	#8-32 x 1/4 TC Class 2 Hwh Zp	03-00962A	ea. 2
54	Hose Clamp	1/2" ID Hose Yellow (F214-DX)	03-01059	ea. 2
82	Screw	#10-24 x 1/2" Slt Hmh Zp (F214-DX)	03-01429	ea. 4
	Hose Clamp	3/4" Hose Blk (F144)	03-01464	ea. 6
	Insert	Bottom Foam (F214, F214-GS)	06-00009	ea. 1
	Insert	Corner Foam (F214, F214-GS)	06-00014	ea. 4
	Box	14" x 12" x 9.125" (F144, F169)	06-00015	ea. 1
	Foam Wrap	6" x 6" x .06" Per Wte .125 (F214-DX)	06-00035	ea. 3
	Insert	Foam 15.5" x 10.5" x 5.5" (F214-DX)	06-00043	ea. 1
	Box	21" x 19.5" x 25.25" (F144, F169)	06-00044	ea. 1
	Foam	Side 2.75 x 2.75 x 21 (F214-DX)	06-00048	ea. 2
	Plastic Bag	9 x 15 2 Mil (F144, F169)	06-00056	ea. 1
31	Label	Product (F214, F214-DX)	07-00299	ea. 1
	Card	Warranty Registration	07-00309	ea. 1
16	Label	Caution Warning	07-01432	ea. 1
26	Coil Assembly	Evaporator / Condensor	08-00023	ea. 1
17	Base	Galvanized	08-00064	ea. 1
29	Cover Assy	w/ Finish	08-00081	ea. 1
34	Filter Shroud	w/ Finish Pc Wr Blk	08-00083	ea. 1
3	Fan/Shroud Assy	Fan shroud assy- 8" 9W 115v	08-00095	ea. 1
22	Gasket	1/2" x 3/16" x 51" Psa	08-00097	ea. 1
27	Gasket	Condenser	08-00102	ea. 1
43	Handle	Chest w/ Finish (F214, F214-GS)	08-00112	ea. 1
81	Hose Wrap	Wire Form w/Pc Wr Blk (F214-DX)	08-00114	ea. 2
66	Leg W/ Finish	Pc Wr Blk	08-00126	ea. 2
67	Handle	Folding, Pc Wr Blk w/ Finish (F214-DX)	08-00128	ea. 1
63	Axle	1/2" Dia x 18.5 w/ Zinc Finish (F214-DX)	08-00130	ea. 1
21	Bulkhead	Galvanized	08-00134	ea. 1
	Refrigerant	R134a (Heat Pipe) (\$25 Flat Fee-no discount)	08-00139	oz. 12
10	Compressor	115v, 3926 BTU Recip 134a	08-00141	ea. 1
23	Drip Tray	ABS Blk	08-00142	ea. 1
38	Flange	Filter Shroud ABS Blk	08-00143	ea. 2
8	Valve	Line Service, 5/16 Dia Copper	08-00144	ea. 1

Find#	Part Description	Specifications/Model	Part #		Qty
40	Power Cord Assy	16/3 SJTW 5-15P, 25Ft	08-00204	ea.	1
74	Relay	115v, PTC Compressor	08-00239	ea.	1
78	Cover	Terminal 3-1/4 x 2-1/8 x 1-3/4 Plastic	08-00246	ea.	1
80	Grommet	.50 ID x 1.125 OD Rubber Blk	08-00249	ea.	4
75	Overload	115v, Compressor	08-00250	ea.	1
76	Clamp	Terminal Cover Spring Stl	08-00251	ea.	1
77	Clip	Compressor Overload	08-00252	ea.	1
79	Sleeve	.375 ID x .50 OD, Compressor 115v	08-00253	ea.	4
7	Defrost Control	115v/230v , Thermostat Spst	08-00308	ea.	1
15	Insulation	Pipe, 3/8" ID x 3/8 Wall	08-00785	ft.	3'
	Tape	1" Blk Med Psa Resil (3")	13-00003	ft.	.25'
70	Foot	Rubber Foot Tip, Blk Rigid Handle 1" ID	13-00510	ea.	2
62	Wheel	9" x 1.75" x 1/2" Bore Black (F214-DX)	13-00861	ea.	2
44	Plug	Metal 1"	13-01190	ea.	2
50	Tubing	1/4" ID x 3/8" OD	15-00195	ft.	40'
55	Tubing	3/8" ID x 1/2" OD Clear Vinyl (2") (F214-DX)	15-01058	ft.	.17'
36	Tubing	1/2" ID x 3/4" OD Clear Vinyl (30") (F214)	15-01463	ft.	2.5'
51	Tubing	1/2" ID x 3/4" OD Clear Vinyl (5") (F214-DX)	15-01463	ft.	.42'
35	Hose End	3/4 Fght x 1/2" HB Nylon	18-00508	ea.	1
	Tubing	1/4" Copper Soft AC/R (F214)	18-00757	ft.	3.13'
	Tubing	5/16" Dia Soft Copper Tube AC/R (F214)	18-00765	ft.	3.49'
53	Hose Barb Fitting	3/8 x 1/4 Nylon Connector (F214-DX)	18-01052	ea.	1

DrizAir 80 Pictorial Drawing

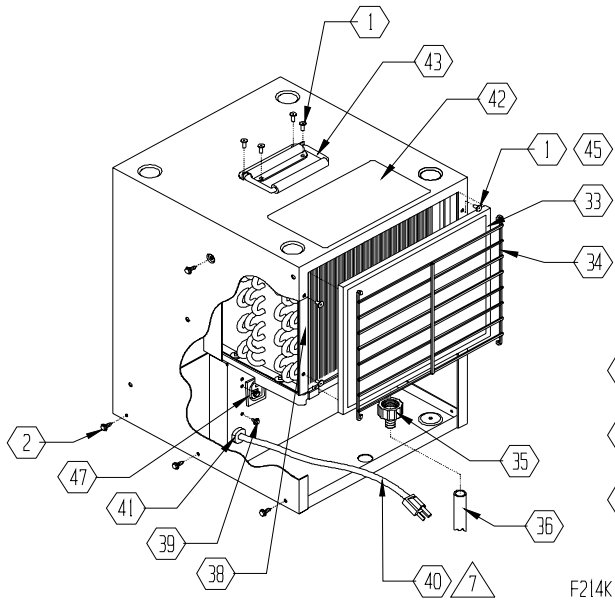
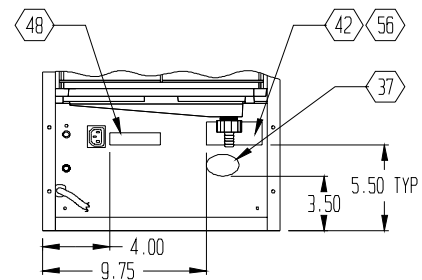
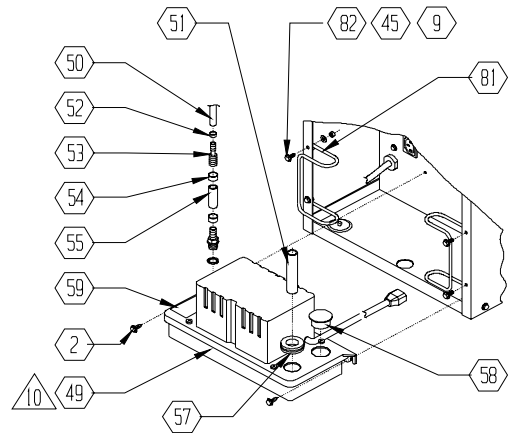
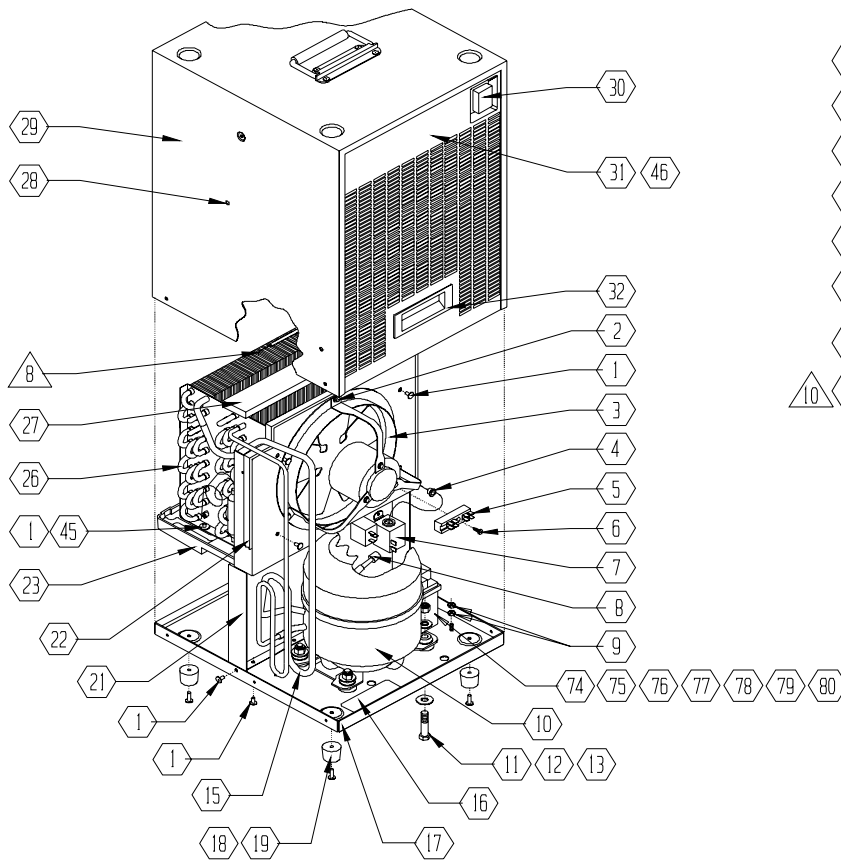

F214K

